

## DETAILS EXPLANATIONS

## ME: Paper-1 (Paper-2) [Full Syllabus]

## [PART : A]

1. The third inversion of double slider crank chain is Oldham's coupling which is used to connect two parallel shafts whose axes are not in perfect alignment. In this inversion, the coupler link 3 is held fixed and the links 2 and 4 have slotted grooves to form sliding pairs with link 1.

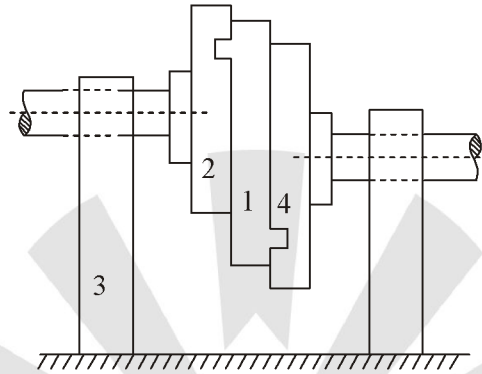

Figure : Oldham's Coupling

2. Number of links,  $n = n_2 + n_3 = 7 + 2 = 9$   
 Number of lower pairs,  $j = \frac{(2n_2 + 3n_3)}{2} = \frac{(2 \times 7 + 3 \times 2)}{2} = 10$   
 $\therefore$  dof =  $3(n - 1) - 2j = 3(9 - 1) - 2 \times 10 = 4$
3. Given,  $P = 120 \text{ kW} = 120 \times 10^3 \text{ W}$   
 $d = 250 \text{ mm}$   
 or  $r = 125 \text{ mm} = 0.125 \text{ m}; N = 650 \text{ r.p.m.}$   
 And  $\omega = 2\pi \times \frac{650}{60} = 68 \text{ rad/s}$   
 $\phi = 20^\circ$   
 Let  $T = \text{Torque transmitted in N-m.}$   
 We know that power transmitted (P),  
 $120 \times 10^3 = t.\omega = T \times 68$   
 or  $T = 120 \times \frac{10^3}{68} = 1765 \text{ N-m}$   
 and tangential load on the pinion,

$$F_T = \frac{T}{r} = \frac{1765}{0.125} = 14120 \text{ N}$$

$\therefore$  Total load due to power transmitted,

$$F = \frac{F_T}{\cos \phi} = 14 \frac{120}{\cos 20^\circ} = 15026 \text{ N} = 15.026 \text{ kN}$$

4. Isochronism is a property by virtue of which a governor keeps constant equilibrium speed for all radii of rotation of the balls within the working range. It is desirable when approximately constant speed is desired to be kept for all loads. In other words, a governor is said to be isochronous governor if the range of speed ( $N_1 - N_2$ ) is zero or its sensitiveness is infinity.

5. A conjugate cam is made of two disc cams, keyed together in such way that makes a positive constraint in touch with two rollers of a follower. These cam are preferred due to low wear and noise in high speed, and high dynamic load.

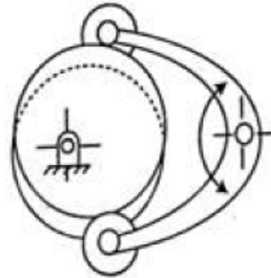

6. Given that,

$$T_g = 200$$

$$F_p = 50$$

Using Relative velocity method

$$\frac{N_p}{N_a} = \frac{T_g}{T_p} + 1 = 5$$

7. It is an alloy of copper, tin and zinc. It usually contains 88% copper, 10% tin and 2% zinc. This metal is also known as Admiralty gun metal. The zinc is added to clean the metal and to increase its fluidity. It is not suitable for being worked in the cold state but may be forged when at about 600°C. The metal is very strong and resistant to corrosion by water and atmosphere. Originally, it was made for casting guns. It is extensively used for casting boiler fittings, bushes, bearings, glands, etc
8. It consists of pressing a metal inside a chamber to force it out by high pressure through an orifice which is shaped to provide the desired form of the finished part. Most commercial metals and their alloys such as steel, copper, aluminium and nickel are directly extruded at elevated temperatures. The rods, tubes, structural shapes, flooring strips and lead covered cables, etc., are the typical products of extrusion.
9. This method is used for reducing the diameter of round bars and tubes by rotating dies which open and close rapidly on the work. The end of rod is tapered or reduced in size by a combination of pressure and impact.
10. **Upper Deviation :**

It is the algebraic difference between the maximum size and the basic size. The upper deviation of a hole is represented by a symbol ES (Ecart Superior) and of a shaft, it is represented by es.

**Lower Deviation :**

It is the algebraic difference between the minimum size and the basic size. The lower deviation of a hole is represented by a symbol EI (Ecart Inferior) and of a shaft, it is represented by ei.

11. Given,

$$P = 50 \text{ kN} = 50 \times 10^3 \text{ N}$$

$$\sigma_t = 75 \text{ MPa} = 75 \text{ N/mm}^2$$

Let,

d = Diameter of the link stock in mm

∴ Area

$$A = \frac{\pi}{4} \times d^2 = 0.7854 d^2$$

We know that the maximum load (P),

$$50 \times 10^3 = \sigma_r A = 75 \times 0.7854 d^2 = 58.9 d^2$$

$$\therefore d^2 = 50 \times \frac{10^3}{58.9} = 850$$

or

$$d = 29.13 \text{ say } 30 \text{ mm}$$

12. Given,
- $$d = 60 \text{ mm}$$
- $$t = 5 \text{ mm}$$
- $$\tau_u = 350 \text{ N/mm}^2$$

We know that area under shear,

$$A = \pi d \times t = \pi \times 60 \times 5 = 942.6 \text{ mm}^2$$

and force required to punch a hole,

$$P = A \times \tau_u = 942.6 \times 350 = 329910 \text{ N} = 329.91 \text{ kN}$$

13. Given :
- $$t = 16 \text{ mm}$$
- $$d = 25 \text{ mm}$$

$$P = 48 \text{ kN} = 48 \times 10^3 \text{ N}$$

Since the joint is double riveted, therefore, strength of two rivets in bearing (or crushing) is taken. We know that crushing stress induced between the plates and the rivets,

$$\sigma_c = \frac{P}{d.t.n} = \frac{48 \times 10^3}{25 \times 16 \times 2} = 60 \text{ N/mm}^2$$

14. It is defined, in general as the ratio of the maximum stress to the working stress. Mathematically,

$$\text{Factor of safety} = \frac{\text{Maximum stress}}{\text{Working or design stress}}$$

In case of ductile materials e.g. mild steel, where the yield point is clearly defined, the factor of safety is based upon the yield point stress. In such cases,

$$\text{Factor of safety} = \frac{\text{Yield point stress}}{\text{Working or design stress}}$$

In case of brittle materials e.g. cast iron, the yield point is not well defined as for ductile materials. Therefore, the factor of safety for brittle materials is based on ultimate stress.

$$\therefore \text{Factor of safety} = \frac{\text{Ultimate stress}}{\text{Working or design stress}}$$

This relation may also be used for ductile materials.

15. When shearing is conducted along a line, the process is referred to as slitting. It cuts the metal sheet lengthwise using suitable punch and die of press tool in press machine.
16. It is defined as the ability of a material to resist deformation under stress. The resistance of a material to elastic deformation or deflection is called stiffness or rigidity. A material that suffers slight or very less deformation under load has a high degree of stiffness or rigidity.
17. Probability of observing studying is given by

$$P = \frac{71}{11 \times 10}$$

Total studying hours in 10 days are

$$10 \times 2.5 = 25 \text{ hours}$$

Therefore, minimum number of hours of study are

$$25 \times P = 16.1364$$

18. Using,

$$Q_s = Q^* \times \sqrt{\frac{s}{s+h}}$$

$$= \sqrt{\frac{2AD}{h}} \times \sqrt{\frac{s}{s+h}} = 838.27$$

19. In a just-in-time (JIT) production system, materials are produced only at the time when they are needed and in required quantity. For this, the companies make agreements with their vendors. This is also called kanban system.

Literal meaning of kanban is visual record, hence it is also known as card system.

20. Stock points are created between adjacent stages of production in order to achieve decoupling of the stages. This is essential to prevent disruptive effect of breakdown on the entire system of production. Stock points are supplied with decoupling inventory.

**[PART : B]**

21. Given that

$$N_R = 0$$

$$N_s = 100 \text{ rpm (clockwise)}$$

Using the tabular algorithm, assuming the arm be fixed, one finds

$$N_A = y$$

$$N_s = x + y$$

$$N_p = -\left(\frac{20}{30}\right)x + y$$

$$N_R = -\frac{20}{30} \times \frac{30}{80}x + y = -\frac{1}{4}x + y$$

Thus,

$$x + y = 100$$

$$-\frac{1}{4}x + y = 0$$

Solving above equations, one finds  $x = \frac{400}{5} = 80$

$$y = 100 - 80 = 20$$

Hence, speed of arm

$$N_A = y = -20 \text{ prm}$$

22. The ratio of tensions on tight and slack sides is related to lap angle  $\theta$ (rad) and coefficient of friction  $\mu$  is

$$\frac{T_1}{T_2} = \exp(m\theta)$$

Thus, the power transmitted can be expressed as

$$P = (T_1 - T_2)v = T_2[\exp(\mu\theta) - 1]v$$

If the lap angle is changed from  $\theta_1$  to  $\theta_2$ , the change in power is determined as

$$\frac{P_2 - P_1}{P_1} = \frac{e^{\mu\theta_2} - e^{\mu\theta_1}}{e^{\mu\theta_1} - 1}$$

Given that,

$$\theta_1 = 150^\circ = 2.617 \text{ rad}$$

$$\theta_2 = 210^\circ = 3.665 \text{ rad}$$

$$\mu = 0.3$$

Hence,

$$\frac{P_2 - P_1}{P_1} = \frac{0.81}{1.1926} = 67.91\%$$

23. The degree of tightness or looseness between the two mating parts is known as a fit of the parts. The nature of fit is characterised by the presence and size of clearance and interference. The clearance is the amount by which the actual size of the shaft is less than the actual size of the mating hole in an assembly as shown in figure (a). In other words, the clearance is the difference between the sizes of the hole and the shaft before assembly. The difference must be positive.

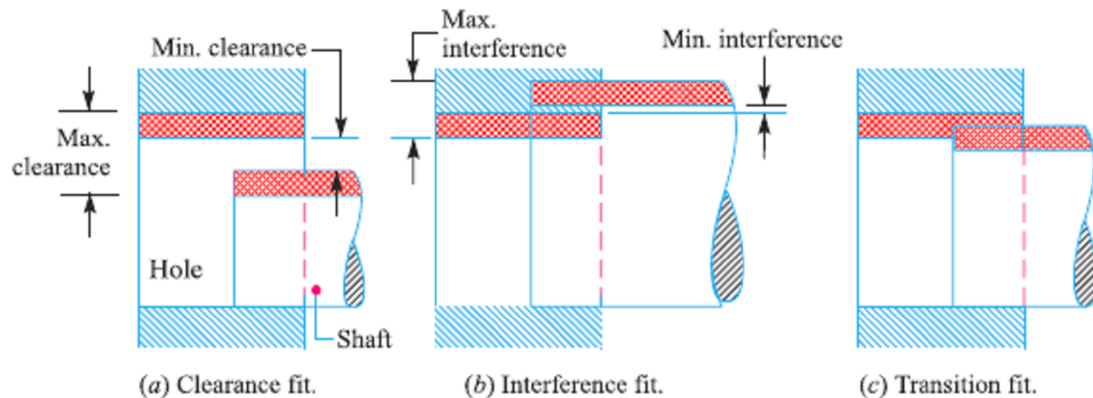

The interference is the amount by which the actual size of a shaft is larger than the actual finished size of the mating hole in an assembly as shown in figure (b). In other words, the interference is the arithmetical difference between the sizes of the hole and the shaft, before assembly. The difference must be negative.

24. Given :
- Lower limit of hole = 2.1 mm
  - Upper limit of hole = 25.02 mm
  - Upper limit of shaft = 24.97 mm
  - Lower limit of shaft = 24.95 mm

**Hole tolerance :**

$$\begin{aligned} \text{We know that hole tolerance} &= \text{Upper limit of hole} - \text{Lower limit of hole} \\ &= 25.02 - 2.1 - 0.02 \text{ mm} \end{aligned}$$

**Shaft tolerance :**

$$\begin{aligned} \text{We know that shaft tolerance} &= \text{Upper limit of shaft} - \text{Lower limit of shaft} \\ &= 24.97 - 24.95 - 0.02 \text{ mm} \end{aligned}$$

**Allowance:** We know that allowance = Lower limit of hole – Upper limit of shaft

$$= 25.00 - 24.97 - 0.03 \text{ mm}$$

25. Given :  $P = 45 \text{ kN} = 45 \times 10^3 \text{ N}$

**Tensile stress induced at section A-A :**

We know that the cross-sectional area of link at section A-A,

$$A_1 = 45 \times 20 = 900 \text{ mm}^2$$

$\therefore$  Tensile stress induced at section A-A,

$$\sigma_{t1} = \frac{P}{A_1} = \frac{45 \times 10^3}{900} = 50 \text{ N/mm}^2 = 50 \text{ MPa}$$

**Tensile stress induced at section B-B :**

We know that the cross-sectional area of link at section B-B,

$$A_2 = 20 (75 - 40) = 700 \text{ mm}^2$$

$\therefore$  Tensile stress induced at section B - B,

$$\sigma_{t2} = \frac{P}{A_2} = \frac{45 \times 10^3}{700} = 64.3 \text{ N/mm}^2 = 64.3 \text{ MPa}$$

26. *The important functions of cutting fluids are given as under :*

- Cutting fluid washes away the chips and hence keeps the cutting region free.
- It helps in keeping freshly machined surface bright by giving a protective coating against atmospheric oxygen and thus protects the finished surface from corrosion.
- It decreases wear and tear of cutting tool and hence increases tool life.
- It improves machinability and reduce power requirements
- It prevents expansion of work pieces.
- It cools the tool and work piece and remove the generated heat from the cutting zone.
- It decreases adhesion between chip and tool; provide lower friction and wear, and a smaller built-up edge.

27. *Blanking :*

It is a operation in which the punch removes a portion of material called blank from the strip of sheet metal of the necessary thickness and width using suitable punch and die of press tool in press machine.

*Punching :*

It is the operation of producing circular holes on a sheet metal by a punch and die. The material punched out is removed as waste. Piercing, on the other hand, is the process of producing holes of any desired shape in the part or sheet using suitable punch and die of press tool in press machine.

*Notching :*

It is a process to cut a specified shape of metal from the side or edge of the stock using suitable punch and die.

28. This process is commonly known as permanent mold casting in U.S.A and gravity die casting in England. A permanent mold casting makes use of a mold or metallic die which is permanent. A typical permanent mold is shown in figure.

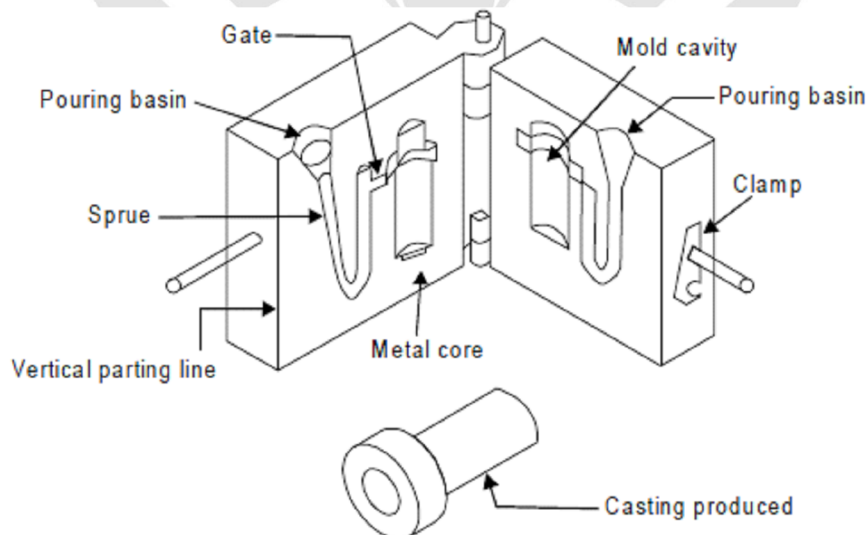

*Figure : A typical permanent mold*

The molten metal is poured into the mold under gravity only and no external pressure is applied to force the liquid metal into the mold cavity.

However, the liquid metal solidifies under pressure of metal in the risers, etc. The metallic mold can be reused many times before it is discarded or rebuilt. These molds are made of dense, fine grained, heat resistant cast iron, steel, bronze, anodized aluminum, graphite or other suitable refractoriness. The mold is made in two halves in order to facilitate the removal of casting from the mold. It may be designed with a vertical parting line or with a horizontal parting line as in conventional sand molds. The mold walls

of a permanent mold have thickness from 15 mm to 50 mm. The thicker mold walls can remove greater amount of heat from the casting. For faster cooling, fins or projections may be provided on the outside of the permanent mold. This provides the desirable chilling effect. There are some advantages, disadvantages and application of this process which are given as under.

**Advantages :**

- Fine and dense grained structure is achieved in the casting.
- No blow holes exist in castings produced by this method.
- The process is economical for mass production.
- Because of rapid rate of cooling, the castings possess fine grain structure.
- Close dimensional tolerance or job accuracy is possible to achieve on the cast product.
- Good surface finish and surface details are obtained.
- Casting defects observed in sand castings are eliminated.
- Fast rate of production can be attained.
- The process requires less labor.

**Disadvantages :**

- The cost of metallic mold is higher than the sand mold. The process is impractical for large castings.
- The surface of casting becomes hard due to chilling effect.
- Refractoriness of the high melting point alloys.

**Applications :**

- This method is suitable for small and medium sized casting such as carburetor bodies, oil pump bodies, connecting rods, pistons etc.
- It is widely suitable for non-ferrous casting

29. The various electrical properties of materials are conductivity, temperature coefficient of resistance, dielectric strength, resistivity, and thermoelectricity. These properties are defined as under.

• **Conductivity :**

Conductivity is defined as the ability of the material to pass electric current through it easily i.e. the material which is conductive will provide an easy path for the flow of electricity through it.

• **Temperature Coefficient of Resistance :**

It is generally termed as to specify the variation of resistivity with temperature.

• **Dielectric Strength :**

It means insulating capacity of material at high voltage. A material having high dielectric strength can withstand for longer time for high voltage across it before it conducts the current through it.

• **Resistivity :**

It is the property of a material by which it resists the flow of electricity through it.

• **Thermoelectricity :**

If two dissimilar metals are joined and then this junction is heated, a small voltage (in the milli-volt range) is produced, and this is known as thermoelectric effect. It is the base of the thermocouple.

Thermo -couples are prepared using the properties of metals

30. **Open Loop Positioning System :**

An open loop positioning systems operates without verifying that the actual position achieved in the move is the same as the desired position. A stepper motor is driven by a series of electrical pulses, which are generated by the MCU in an NC system. Each pulse causes the motor to rotate a fraction of one revolution called step angle, denoted by  $\alpha$ .

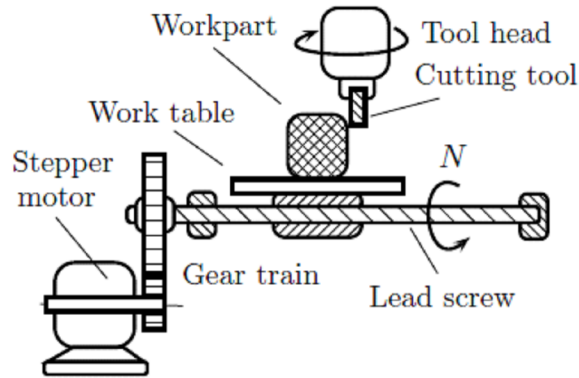

Figure : NC Positioning system

Consider an open loop positioning system in which the stepper motor has  $n_s$  number of step angles of equal value  $\alpha$  ( $= 360/n_s$  degrees) and lead screw has a pitch ( $p$ ). Transfer of angular rotation of the stepper motor to lead screw is reduced through a gear train having a gear ratio ( $r_g > 1$ ) (defined as the number of turns of the motor for each single turn of the lead screw). The angle turned by the motor shaft ( $\theta_m$ ) for number of pulses  $n_p$  would be given by

$$\theta_m = n_p \alpha$$

The angle turned by lead screw ( $\theta_l$ ) for  $n_p$  pulses is given by

$$\theta_l = \frac{\theta_m}{r_g} = \frac{n_p \alpha}{r_g}$$

Linear movement of the work table for  $n_p$  pulses is determined as

$$x = p \times \frac{\theta_l}{360} = \frac{pn_p \alpha}{360r_g}$$

Thus, the number of pulses required for movement  $x$  are given by

$$n_p = \frac{360xr_g}{p\alpha}$$

Angular speed  $N$  (rpm) of the lead screw for pulse train frequency  $f_p$  (Hz) is given by

$$\frac{N}{60} r_g = \frac{f_p}{n_s}$$

$$N = \frac{60f_p}{n_s r_g}$$

The table speed ( $v$ ) can be determined as

$$v = Np = \frac{60f_p p}{n_s r_g}$$

31. Given that

$$U = 2.0 \text{ J/mm}^3$$

$$V_c = 120 \text{ m/min} = 2000 \text{ mm/s}$$

$$f = 0.2 \text{ mm/rev}$$

$$d = 2 \text{ mm}$$

Rate of material removal is  $MRR = V_c \times f \times d$

There seems a mistake in the given data. The specific energy  $U$  should be  $2 \text{ kJ/mm}^3$  to get  $F_c = 800 \text{ N}$ .

The cutting force is written as

$$F_c = \frac{U \times MRR}{V_c} = U \times f \times d = 0.80 \text{ N}$$



32. Given that  $\phi = 20^\circ$  and  $\alpha = 0^\circ$

$$\begin{aligned} \text{Using} \quad 2\phi + \lambda - \alpha &= \frac{\pi}{2} \\ \lambda &= 50^\circ \end{aligned}$$

The ratio of forces is obtained as  $\frac{F}{N} = \tan\lambda = 1.19175$

**[PART : C]**

33. Given:

$$W_{\min} = 200 \text{ kN}$$

$$W_{\max} = 500 \text{ kN}$$

$$\sigma_u = 100 \text{ MPa} = 900 \text{ N/mm}^2$$

$$\sigma_e = 700 \text{ MPa} = 700 \text{ N/mm}^2$$

$$(F.S.)_u = 3.5 ; (F.S.)_e = 4 ; K_f = 1.65$$

Let  $d = \text{Diameter of bar in mm.}$

$$\therefore \text{Area} \quad A = \frac{\pi}{4} \times d^2 = 0.7854 d^2 \text{ mm}^2$$

We know that mean or average force

$$W_m = \frac{W_{\max} + W_{\min}}{2} = \frac{500 + 200}{2} = 350 \text{ kN} = 350 \times 10^3 \text{ N}$$

$$\therefore \text{Mean stress} \quad \sigma_m = \frac{W_m}{A} = \frac{350 \times 10^3}{0.7854 d^2} = \frac{446 \times 10^3}{d^2} \text{ N/mm}^2$$

$$\text{Variable stress,} \quad W_v = \frac{W_{\max} - W_{\min}}{2} = \frac{500 - 200}{2} = 150 \text{ kN} = 150 \times 10^3 \text{ N}$$

$$\therefore \text{Variable stress} \quad \sigma_v = \frac{W_v}{A} = \frac{150 \times 10^3}{0.7854 d^2} = \frac{191 \times 10^3}{d^2} \text{ N/mm}^2$$

We know that according to Goodman's formula,

$$\begin{aligned} \frac{\sigma_v}{\sigma_e / (F.S.)_e} &= 1 - \frac{\sigma_m \cdot K_f}{\sigma_u / (F.S.)_u} \\ \frac{191 \times 10^3}{700/4} &= 1 - \frac{446 \times 10^3 \times 1.65}{900/3.5} \end{aligned}$$

$$\frac{1100}{d^2} = 1 - \frac{2860}{d^2}$$

$$\text{or} \quad \frac{1100 + 2860}{d^2} = 1$$

$$\therefore \quad d^2 = 3960 \text{ or } d = 62.9 \text{ say } 63 \text{ mm}$$

34. Given :

$$P = 100 \text{ kW} = 100 \times 10^3 \text{ W}$$

$$*N = 2400 \text{ r.p.m.}$$

$$T = 500 \text{ N-m} = 500 \times 10^3 \text{ N-mm}$$

$$p = 0.07 \text{ N/mm}^2$$

$$\mu = 0.3$$

$$\text{Number of springs} = 8$$

$$\text{Stiffness/spring} = 40 \text{ N/mm}$$

*Dimensions of the friction plate :*

Let  $r_1$  = Outer radius of the friction plate,

and  $r_2$  = Inner radius of the friction plate

Since the outer radius of the friction plate is 25% more than the inner radius, therefore

$$r_1 = 1.25 r_2$$

For uniform wear conditions,  $p.r = C$  (a constant). Since the intensity of pressure is maximum at the inner radius ( $r_2$ ), therefore

$$p.r_2 = C \text{ or } C = 0.07r_2 \text{ N/mm}$$

and axial load acting on the friction plate,

$$\begin{aligned} W &= 2\pi C (r_1 - r_2) = 2\pi \times 0.07 r_2 (1.25 r_2 - r_2) \\ &= 0.11 (r_2)^2 \text{ N} \end{aligned} \quad \dots(1)$$

We know that mean radius of the friction plate, for uniform wear

$$R = \frac{r_1 + r_2}{2} = \frac{1.25r_2 + r_2}{2} = 1.125 r_2$$

$\therefore$  Torque transmitted (T),

$$500 \times 10^3 = n.\mu.W.R = 2 \times 0.3 \times 0.11(r_2)^2 \cdot 1.125r_2 = 0.074 (r_2)^3 \quad \dots(\because n = 2)$$

$$(r_2)^3 = 200 \times \frac{10^3}{0.074} = 6757 \times 10^3 \text{ or } r_2 = 190 \text{ mm}$$

and  $r_1 = 1.25 r_2 = 1.25 \times 190 = 237.5 \text{ mm}$

*Initial compression in the springs :*

We know that total stiffness of the springs,

$$\begin{aligned} s &= \text{Stiffness per spring} \times \text{Number of springs} \\ &= 40 \times 8 = 320 \text{ N/mm} \end{aligned}$$

Axial force required to engage the clutch,

$$W = 0.11(r_2)^2 = 0.11(190)^2 = 3970 \text{ N} \quad [\text{From equation (1)}]$$

$\therefore$  Initial compression in the springs,

$$= \frac{W}{s} = \frac{3970}{320} = 12.4 \text{ mm}$$

35. In designing various parts of a machine, it is necessary to know how the material will function in service. For this, certain characteristics or properties of the material should be known. The mechanical properties mostly used in mechanical engineering practice are commonly determined from a standard tensile test. This test consists of gradually loading a standard specimen of a material and noting the corresponding values of load and elongation until the specimen fractures. The load is applied and measured by a testing machine. The stress is determined by dividing the load values by the original cross-sectional area of the specimen. The elongation is measured by determining the amounts that two reference points on the specimen are moved apart by the action of the machine. The original distance between the two reference points is known as gauge length. The strain is determined by dividing the elongation values by the gauge length.

The values of the stress and corresponding strain are used to draw the stress-strain diagram of the material tested. A stress-strain diagram for a mild steel under tensile test is shown in. The various properties of the material are discussed below :

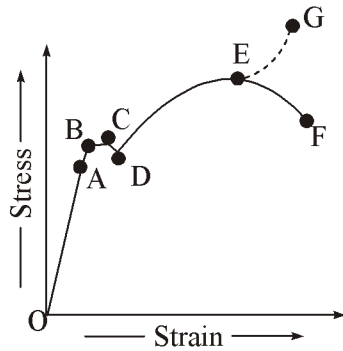

Figure (a)

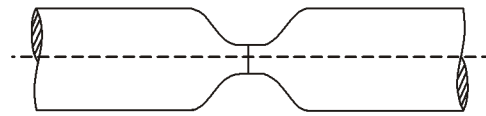

Figure (b) Shape of specimen after elongation

Figure : Stress-strain diagram for a mild steel

- **Proportional limit :**

We see from the diagram that from point O to A is a straight line, which represents that the stress is proportional to strain. Beyond point A, the curve slightly deviates from the straight line. It is thus obvious, that Hooke's law holds good up to point A and it is known as proportional limit. It is defined as that stress at which the stress-strain curve begins to deviate from the straight line.

- **Elastic limit :**

It may be noted that even if the load is increased beyond point A upto the point B, the material will regain its shape and size when the load is removed. This means that the material has elastic properties up to the point B. This point is known as elastic limit. It is defined as the stress developed in the material without any permanent set.

*Note: Since the above two limits are very close to each other, therefore, for all practical purposes these are taken to be equal.*

- **Yield point :**

If the material is stressed beyond point B, the plastic stage will reach i.e. on the removal of the load, the material will not be able to recover its original size and shape. A little consideration will show that beyond point B, the strain increases at a faster rate with any increase in the stress until the point C is reached. At this point, the material yields before the load and there is an appreciable strain without any increase in stress. In case of mild steel, it will be seen that a small load drops to D, immediately after yielding commences. Hence there are two yield points C and D. The points C and D are called the upper and lower yield points respectively. The stress corresponding to yield point is known as yield point stress.

- **Ultimate stress**

At D, the specimen regains some strength and higher values of stresses are required for higher strains, than those between A and D. The stress (or load) goes on increasing till the point E is reached. The gradual increase in the strain (or length) of the specimen is followed with the uniform reduction of its cross-sectional area. The work done, during stretching the specimen, is transformed largely into heat and the specimen becomes hot. At E, the stress, which attains its maximum value is known as ultimate stress. It is defined as the largest stress obtained by dividing the largest value of the load reached in a test to the original cross-sectional area of the test piece.

- **Breaking stress :**

After the specimen has reached the ultimate stress, a neck is formed, which decreases the cross-sectional area of the specimen, as shown in figure (b). A little consideration will show that the stress (or load) necessary to break away the specimen, is less than the maximum stress. The stress is, therefore, reduced until the specimen breaks away at point F. The stress corresponding to point F is known as breaking stress.

- **Percentage reduction in area :**

It is the difference between the original cross-sectional area and cross-sectional area at the neck (i.e. where the fracture takes place). This difference is expressed as percentage of the original cross-sectional area.

Let  $A$  = Original cross-sectional area

and  $a$  = Cross-sectional area at the neck

Then reduction in area =  $A - a$

and percentage reduction in area =  $\frac{A-a}{A} \times 100$

- **Percentage elongation :**

It is the percentage increase in the standard gauge length (i.e. original length) obtained by measuring the fractured specimen after bringing the broken parts together.

Let  $l$  = Gauge length or original length

and  $L$  = Length of specimen after fracture or final length.

∴ Elongation =  $L - l$

and percentage elongation =  $\frac{L-l}{l} \times 100$

### 36. TYPES OF LAYOUTS :

The fulfilling the objectives of a good layout as per yearly product requirement and product types, the layouts are classified into four major categories namely fixed or position layout, line or product layout, process or functional layout and combination or group layout. Each kind of layouts is explained with respective merit, demerits and application as under.

#### Fixed or Position Layout :

Fixed or position layout is also known as project layout. A typical fixed layout is shown in figure. In this type of layout the major part of an assembly or material remains at a fixed position. All its accessories, auxiliary material, machinery, equipment needed, tools required and the labor are brought to the fixed site to work. Thus, the product by virtue of its bulk or weight remains at one location. Therefore the location of the major assembly, semi assembly component and material is not disturbed till the product is ready for dispatch. This layout is suitable when one or a few pieces of an item are to be manufactured and material forming or treating operation requires only tools or simple machines. This layout is highly preferable when the cost of moving the major piece of material is high and the responsibility of product quality by one skilled workman or group of skilled workers is expected. This type of layout is mainly adopted for extremely large items manufactured in very small quantity such as ships, aero planes, boilers, reactors etc. Its main merit of this layout is the minimum movement of men, material, and tooling during manufacturing process. This layout is highly flexible as the type of product and the related processes can be easily changed without any change in the layout. The merit and demerit of this type of layout is given as under.

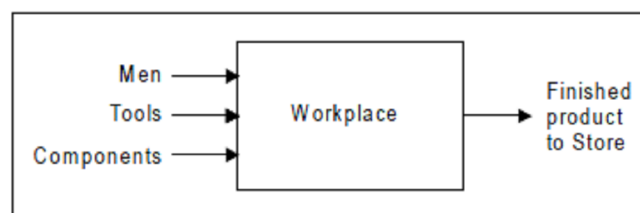

Figure : Typical project layout

*Merits : Its main merits are :*

- Layout is highly flexible for varieties of products having intermittent demand as the type of product and the related processes can be easily altered without any change in the layout.
- There is a minimum movement of men, material, and tooling during manufacturing process.
- The material is drastically reduced.
- Highly skilled operators are required to complete the work at one point and responsibility for quality is fixed on one person or the assembly crew.
- Every personnel of manufacturing team is responsible for quality work for manufacturing the product.

*Demerits : The major demerits of this layout are :*

- The cost of equipment handling is very high.
- Labors and equipments are difficult to utilize fully.
- It is limited to large items only.

*Applications :*

This type of layout is mostly adopted for extremely large items manufactured in very small quantity such as ships, aero planes, aircraft, locomotive, ship assembly shops, shipyards, boilers, reactors etc.

### Process or Functional Layout :

A typical process or functional layout is shown in figure. In this type of layout arrangements of similar machines, production facilities and manufacturing operations are grouped together Plant and Shop Layout 21 according to their functions. Machine tools of one kind are positioned together so that all the similar operations are performed always at the same place e.g. all the lathes may be grouped together for all kinds of turning and threading operations, all drilling machines in one area for carrying out drilling work, all tapping machines in one area for carrying out tapping work, all milling machines in one area for carrying out milling work all buffing and polishing machines at one place for carrying out surface finishing work, and so on. This type of layout is normally preferred for the industries involved in job order type of production and manufacturing and/or maintenance activities of non- repetitive type. This layout needs not to have to be changed every time of the product or component changes. Also the breakdown of any machine does not affect the production. This type of layout is highly suitable for batch production.

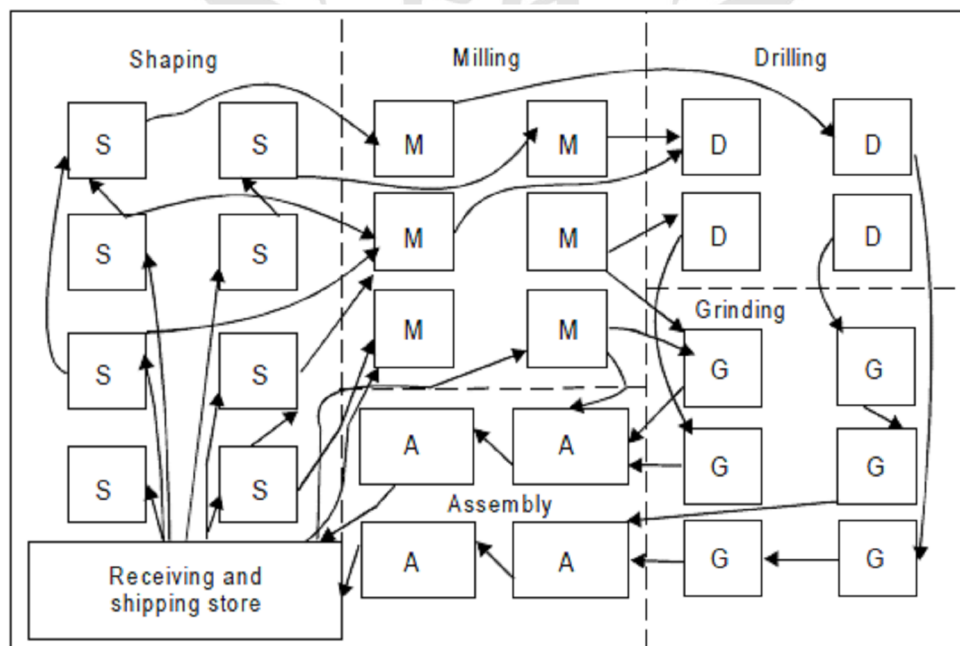

*Figure : Typical Functional layout*

*Merits : The major merits of this layout are :*

- There exists a wide flexibility regarding allotment of work to equipment and workers.
- There is a better utilization of the available equipment.
- Comparatively less numbers of machines are needed in this layout and hence thus reducing capital investment.
- There is an improved product quality, because the supervisors and workers attend to one type of machines and operations.
- Varieties of jobs coming as different job orders thus make the work more interesting for the workers.
- Workers in one section are not affected by the nature of the operations carried out in another section. For example, a lathe operator is not affected by the rays of the welding as the two sections are quite separate.

*Demerits : The major demerits of this layout are :*

- This layout requires more space in comparison to line or product layout for the same amount of production.
- Production control becomes relatively difficult in this layout.
- Raw material has to travel more which increases material handling and the associated costs.
- This layout requires more efficient co-ordination and inspections.
- Increased material handling cost due to more movement of process raw material to various paths
- More material in process remains in queue for further operations.
- Requires large in-process inventory.
- Completion of same product takes more time.

*Application :*

- This layout is used for batch or moderate production.
- It specify path for group technology.

### **Line or Product Layout :**

A typical line or product layout is shown in figure . This layout implies that various operations on raw material are performed in a sequence and the machines are placed along the product flow line, i.e., machines are arranged in the sequence in which the raw material will be operated upon. In this type of layout all the machines are placed in a line according to the sequence of operations, i.e., each following machine or section is arranged to perform the next operation to that performed by its preceding machine or section. In this layout raw material starts from one end of production lines and moves from one machine to next along a sequential path. Line layout is advantages in the continuous- production system where the number of end products is small and the parts are highly standardized and interchangeable. It is suitable for products having steady demand. This layout may have operational sequence namely forging, turning, drilling, milling, grinding and inspection before the product is sent to the finished goods store for packing and shipment. This layout is used for mass production and ensures smooth flow of materials and reduced material handling. Breakdown of any machine in the line in this layout may result in even stoppage of production.



*Figure : Typical line layout*

*Merits : Its main merits are :*

- It involves smooth and continuous work flow.
- It may require less skilled workers
- It helps in reducing inventory.
- Production time is reduced in this layout.
- Better coordination, simple production planning and control are achieved in this layout.
- For the same amount of production, less space requirements for this layout.
- Overall processing time of product is very less.
- This layout involves automatic material handling, lesser material movements and hence leads to minimum possible cost of manufacturing.

*Demerits : The major demerits of this layout as compared with process layout are :*

- It is very difficult to increase production beyond the capacities of the production lines.
- When single inspector has to look after many machines, inspection becomes difficult
- This layout is very less flexible for product change.
- The rate or pace rate of working depends upon the output rate of the slowest machine and hence leading to excessive idle time for other machines if the production line is not adequately balanced.
- Machines being put up along the line, more machines of each type have to be installed for keeping a few as stand by, because if on machine in the line fails, it may lead to shut down of the complete production line. That is why the line or product layout involves heavy capital investments.

*Applications :*

- It is used in assembly work.

### Combination Layout :

Figure shows a typical combination type of layout for manufacturing different sizes of crank shafts. It is also known as group layout. A combination of process and product layouts combines the advantages of both types of layouts. Most of the manufacturing sections are arranged in process layout with manufacturing lines occurring here and there scattered wherever the conditions permit. These days, the most of manufacturing industries have adopted this kind of layout. In this type of layout, a set of machinery or equipment is grouped together in a section, and so on, so that each set or group of machines or equipment is used to perform similar operations to produce a family of components. A combination layout is and manufacturing equipments are arranged in a process layout but a group of number of similar machines is then arranged in a sequence to manufacture various types and sizes of products.

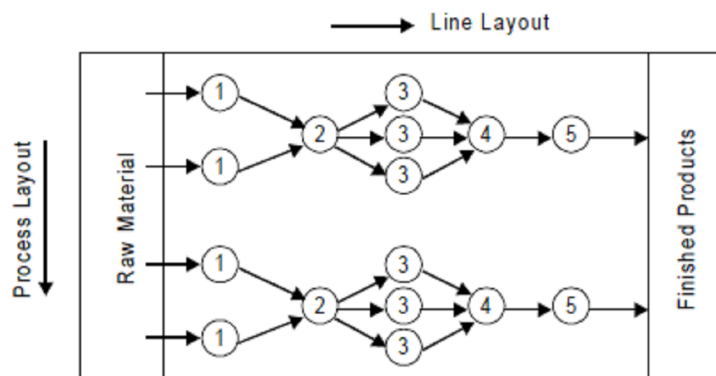

*Figure : Typical combination layout*

In this layout, it is noted that, no matter the product varies in size and type, the sequence of operations remain same or similar. This layout is suitable when similar activities are performed together thereby avoiding wasteful time in changing from one unrelated activity to the next. It focuses on avoiding unnecessary duplication of an effort. It is preferable for storing and retrieving information changing related to recurring problems thereby reducing the search time understanding information and eliminating the need to solve the problem again. It is also useful when a number of items are produced in same sequence but none of the items are to be produced in bulk and thus no item justifies for an individual and independent production line.

*There are some merits, demerits and application of this layout which are given as under :*

*Merits : The merits of this type of layout are:*

- Reduction in cost of machine set-up time and material handling of metals.
- Elimination of excess work-in-process inventory which subsequently allows the reduction in lot size.
- Simplification of production planning functions, etc.

*Demerits : The major demerits of this layout are :*

- Change of the existing layout is time consuming and costly.
- Inclusion of new components in the existing component requires thorough analysis.
- Change of input component mix may likely to change complete layout structure.
- Change of batch size may change number of machines.

*Application :*

- Manufacturing circular metal saws, hacksaw, wooden saw, files and crank shaft.

37. *There are two distinct methods of milling classified as follows:*

- Up-milling or conventional milling.
- Down milling or climb milling.

### **UP-Milling or Conventional Milling Procedure**

In the up-milling or conventional milling, as shown in Figure , the metal is removed in form of small chips by a cutter rotating against the direction of travel of the workpiece. In this type of milling, the chip thickness is minimum at the start of the cut and maximum at the end of cut. As a result the cutting force also varies from zero to the maximum value per tooth movement of the milling cutter. The major disadvantages of up-milling process are the tendency of cutting force to lift the work from the fixtures and poor surface finish obtained. But being a safer process, it is commonly used method of milling.

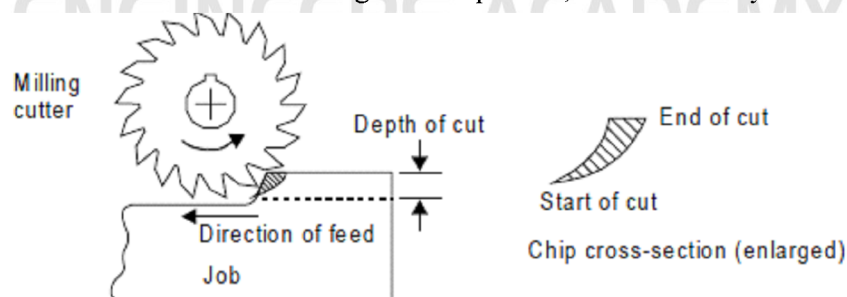

*Figure : Principal of up-milling*

### **Down-Milling or Climb Milling :**

Down milling is shown in figure It is also known as climb milling. In this method, the metal is removed by a cutter rotating in the same direction of feed of the workpiece. The effect of this is that the teeth cut downward instead of upwards. Chip thickness is maximum at the start of the cut and minimum in



the end. In this method, it is claimed that there is less friction involved and consequently less heat is generated on the contact surface of the cutter and workpiece. Climb milling can be used advantageously on many kinds of work to increase the number of pieces per sharpening and to produce a better finish. With climb milling, saws cut long thin slots more satisfactorily than with standard milling. Another advantage is that slightly lower power consumption is obtainable by climb milling, since there is no need to drive the table against the cutter.

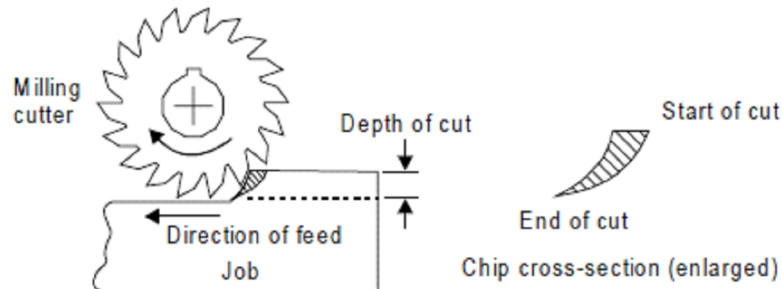

Figure : Principal of down milling

38. Basic Principle Electron-beam machining (EBM) is a thermoelectric process in which a stream of high-speed electrons impinges on the work surface whereby the kinetic energy converts into thermal energy of extremely high density that melts or vaporizes the work material in a very localized area.

Basic Elements To avoid a collision of the accelerating electrons with the air molecules, the process has to be conducted in vacuum (about 10 – 5 mm Hg). Electron beam gun uses voltages in the range of 50 – 200 kV to generate a continuous stream of electrons and accelerated to 50 – 80% of the speed of light. Effective control of the electromagnetic lens on the workpiece enables drilling fine holes and cutting narrow slots.

*Merits EBM offers the following advantages :*

- Specially adopted for micro-machining.
- Suitable for high-strength materials.
- Offers high degree of automation and mass production.
- Extremely close tolerances.

**Demerits EBM has the following limitations:**

- Vacuum chamber restricting the size of workpiece.
- Time is required for evacuating the chamber.
- Emission of X-ray due to interaction of electron beam with workpiece.
- High specific energy consumption.
- High equipment cost and need for skilled operators.

*Applications :*

EBM finds applications in drilling fine holes of the order of 25 – 125  $\mu\text{m}$  and silting narrow cuts upto 25  $\mu\text{m}$  on 0.25 – 6.3 mm thick plates. EBM is used for perforating the filters and screens in textile and chemical industries.

39. Let

$$x_2 = \text{Deflection of spring} = R.\theta$$

$$\text{Spring force} = kx_2 = k.R.\theta$$

$$x_1 = r.\theta = \text{downward movement of mass } m$$

$$\text{Total Kinetic energy} = \text{K.E. of the mass} + \text{K.E. of rotating element}$$

$$= \frac{1}{2} m \dot{x}_1^2 + \frac{1}{2} I \dot{\theta}^2$$

$$\text{Potential energy of spring} = \frac{1}{2} k x_2^2$$

$$\text{Total energy} = \frac{1}{2} m \dot{x}_1^2 + \frac{1}{2} I \dot{\theta}^2 + \frac{1}{2} k x_2^2$$

By energy method, we get

$$\frac{1}{2} m \dot{x}_1^2 + \frac{1}{2} I \dot{\theta}^2 + \frac{1}{2} k x_2^2 = \text{constant}$$

Differentiating the above expression w.r.t. time, we get

$$\frac{d}{dt} \left[ \frac{1}{2} m r^2 \dot{\theta}^2 + \frac{1}{2} I \dot{\theta}^2 + \frac{1}{2} k R^2 \theta^2 \right] = \frac{d}{dt} (\text{Contt})$$

$$m r^2 \dot{\theta} \ddot{\theta} + I \dot{\theta} \ddot{\theta} + k R^2 \theta \dot{\theta} = 0$$

$$(m r^2 + I) \ddot{\theta} + k R^2 \theta = 0$$

$$\ddot{\theta} + \left( \frac{k R^2}{m r^2 + I} \right) \theta = 0$$

$$\omega_n = \sqrt{\frac{k R^2}{m r^2 + I}}$$

$$f_n = \frac{1}{2\pi} \sqrt{\frac{k R^2}{m r^2 + I}}$$

○○○

ENGINEERS ACADEMY